

Installation Instructions for Arbiter Systems GPS Antenna Mounting Bracket

Order Number AS0044600

Introduction

The AS0044600 GPS Antenna Mounting Bracket is designed specifically for use with antennas shipped with Arbiter Systems GPS-Controlled Clocks. The hardware included with the bracket allows installation of the antenna on a mast or pipe up to about 2" in diameter, and a different clamp may be substituted for use with a larger diameter pipe. Also, the bracket can be mounted to a wall, a roof, or any other flat surface.

Additionally, the antenna may be rotated to compensate for mounting to objects or surfaces that are not perfectly vertical or horizontal. This allows optimum positioning of the antenna for the best possible satellite reception.

Parts List

The following parts are included with in the Antenna Mounting Bracket Kit:

Qty.	Description	ASI P/N
1	GPS antenna mounting bracket	HD0052700
1	U-bolt, 1-1/8", stainless steel, with 2 hex nuts	HP0014700
1	3/4" x 4" threaded pipe, PVC, schedule 80	HP0014804
1	Hose clamp, worm-drive, stainless steel	HP0014900
1	Mounting bracket stabilizer, stainless steel	HD0054200

Tools Required

The following tools will be necessary to install the GPS antenna mounting bracket:

- Needle nosed pliers
- 7/16" open-end wrench
- 5/16" nutdriver, or flat-blade screwdriver

Installation Instructions

The following sections describe the steps necessary for proper installation of the GPS antenna using the mounting bracket.

Antenna Preparation

Prior to installation of the GPS antenna to the bracket, it must be configured as follows.

1. Using a pair of needle nosed pliers, remove the protective rubber grommet from the “F” style connector on the GPS antenna. Use caution to avoid damaging the threads.
2. Thread one end of the coaxial antenna cable through the center of the PVC pipe, then attach the male F connector on the end of the cable to the female F connector on the antenna. Using a 7/16” open-end wrench, snug the barrel of the male connector. Do not over-tighten.
3. Thread the end of the PVC pipe into the base of the antenna, and hand tighten.

Mounting the Antenna Assembly to the Bracket

The bracket included with the kit features holes designed to accommodate numerous different mounting configurations. Figure 1 shows the bracket, and the locations of these holes.

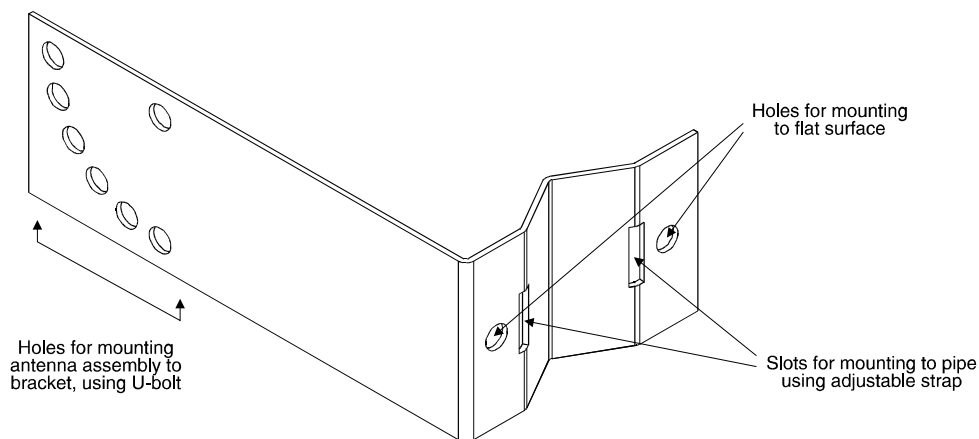
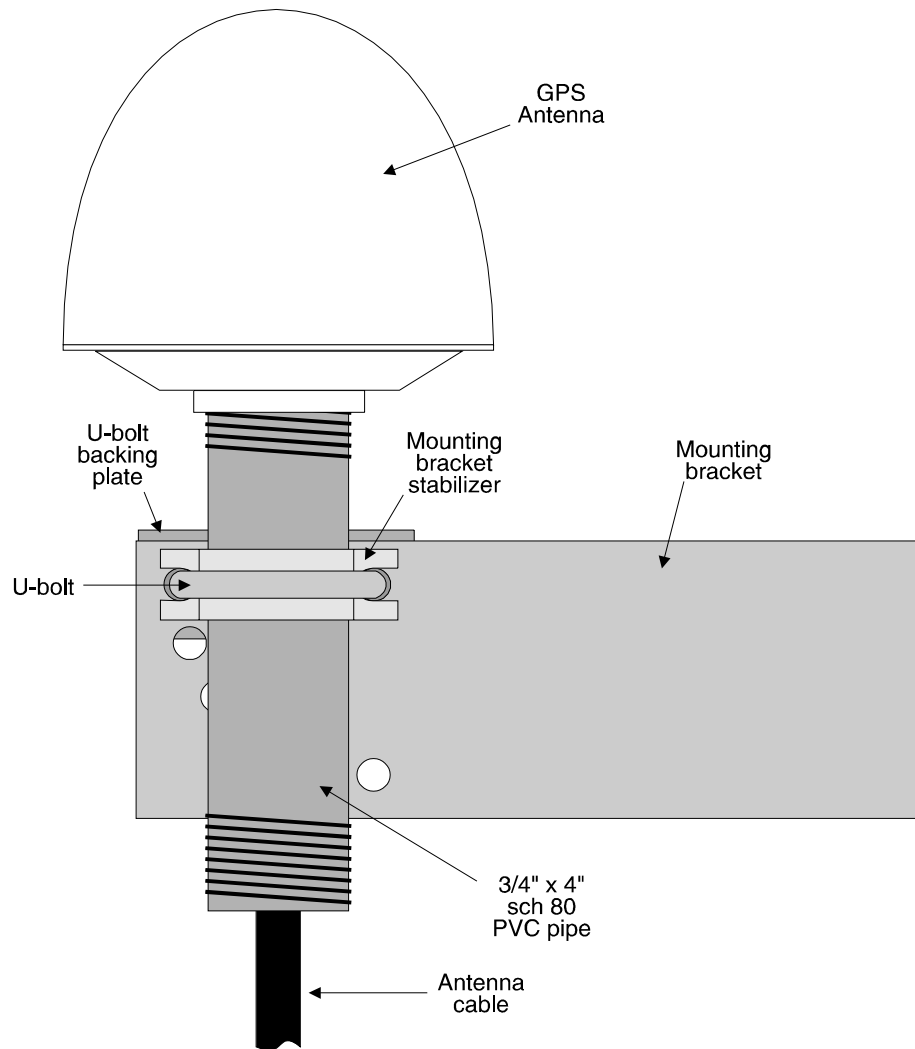

Figure 1

GPS Antenna Mounting Bracket

Typically, it is a good idea to mount the bracket to the surface or mast prior to installing the antenna assembly. However, it is important to understand how the finished assembly goes together in order to properly orient the bracket. Refer to Figure 2 and the following instructions for details on mounting the antenna assembly to the bracket.

**Figure 2****Mounting the Antenna Assembly to the Bracket**

1. Slip the ends of the U-bolt through the two slots on the mounting bracket stabilizer, so that the stabilizer is nested in the U-bolt.
2. Place the U-bolt and stabilizer over the 4" length of PVC pipe to which the antenna is mounted.
3. Feed the ends of the U-bolt through the appropriate holes on the mounting bracket, as shown in Figure 2. Note: For mounting surfaces that are not perfectly horizontal or vertical, refer to the section describing angled mounting.
4. Place the backing plate over the ends of the U-bolt, and thread on the two 1/4-20 hex nuts. Tighten the nuts using the 7/16" nut driver. Use care to avoid damaging the PVC pipe by over-tightening.

Mounting the Bracket to a Flat Surface

The mounting bracket features two holes which may be used to secure it to a flat surface, using lag screws, machine bolts, anchor bolts, etc. Refer to Figure 1 for the location of these holes.

The mounting holes are designed to accommodate any 1/4" hardware. Figure 3 shows the bracket and antenna assembly configured for mounting to a flat vertical surface. If the surface is not perfectly vertical or horizontal, refer to the section describing angled installations.

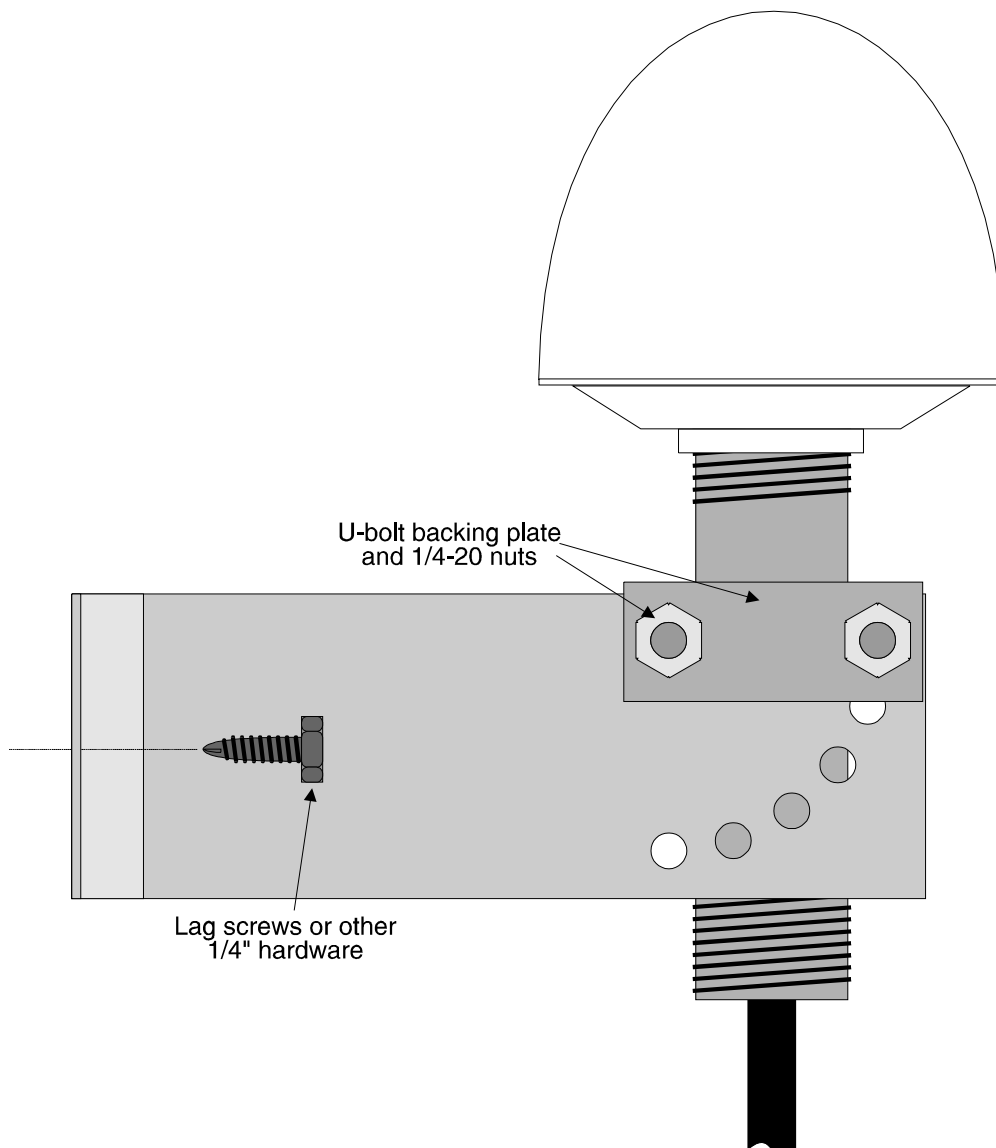

Figure 3

Mounting the Bracket to a Flat Surface

PD0024700

Mounting the Bracket to a Pipe

The mounting bracket also features two slots to accommodate a worm-drive adjustable clamp, which is included with the kit. This allows attachment to pipes up to two inches in diameter. Refer to Figure 1 for the location of the slots.

To install the antenna bracket using the adjustable clamp, refer to Figure 4 and the following instructions.

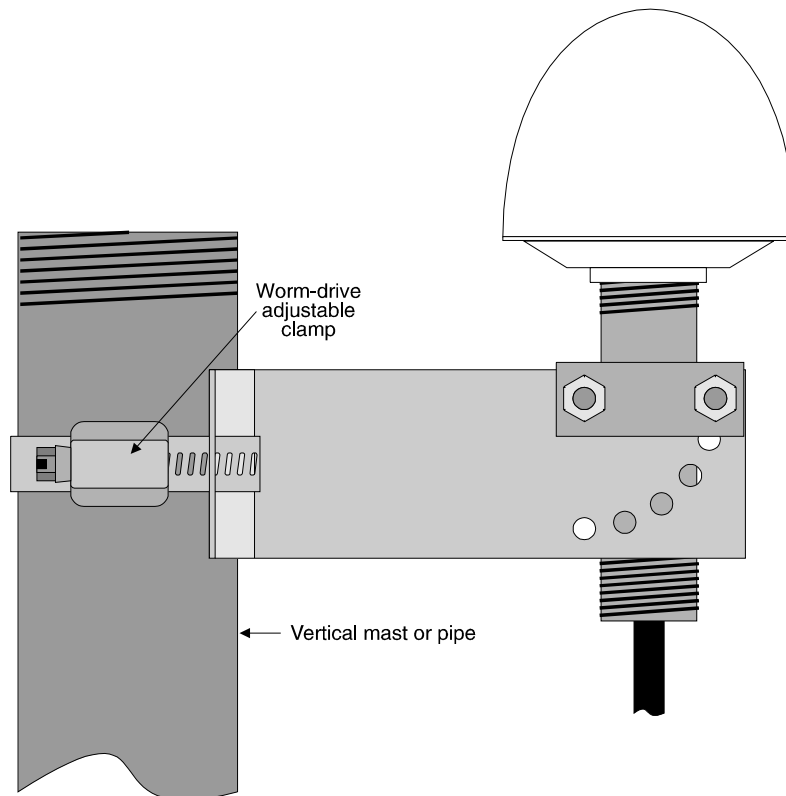

Figure 4

Mounting the Bracket to a Pipe or Mast

1. Open the worm-drive clamp by turning the adjusting screw counter-clockwise, using a 5/16" nut driver or flat-bladed screwdriver.
2. Insert the free end of the clamp into one of the slots in the bracket, and feed it back out through the other slot.
3. If the mast or pipe has an exposed end over which the bracket assembly can be lowered, re-insert the free end of the clamp into the adjusting screw. Otherwise, leave the clamp open.
4. Attach the bracket to the mast or pipe, and tighten, using the 5/16" nut driver or flat-bladed screwdriver. Optionally, a small band of neoprene rubber or similar material may be used under the clamp to prevent slippage.

Mounting the Bracket to an Angled Object or Surface

In any GPS timing installation, it is important to ensure that the antenna is oriented as near to horizontal as possible. This will provide the largest possible view of the sky, resulting in optimum satellite coverage. Failure to observe this requirement will increase the likelihood that interruptions to satellite synchronization will occur. This may cause timing performance degradation, especially if the loss occurs for prolonged periods. Following is a brief description of measures that can be taken to facilitate antenna mounting to angled objects or surfaces, while keeping the antenna orientation as flat as possible.

Figure 5 shows the antenna bracket assembly mounted to a pipe that is at an angle. Additional holes were included on the bracket to accommodate such installations (refer to Figure 1). These holes will allow adjustment of the antenna angle in 18° increments.

By utilizing the additional holes and changing the orientation of the bracket, it should be possible to compensate for any angle encountered in either a mast-mounted or surface-mounted installation.

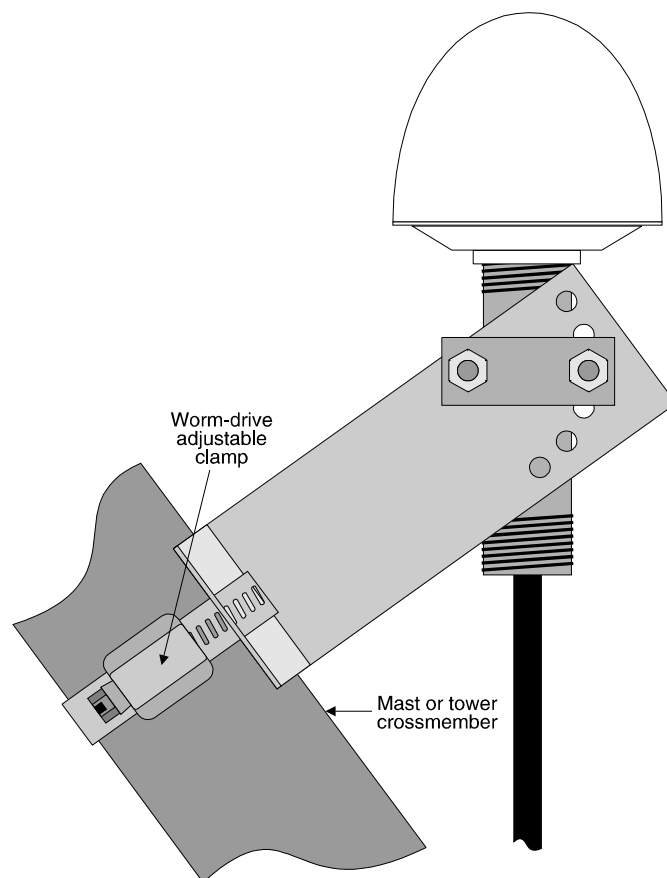

Figure 5

Mounting the Bracket to an Angled Object